



3A165

Type	Rated RPM	Rated Power (kW/HP)	Max. Torque (N·m/rpm)
3A165-SE4A	2600	18.3 / 24.5	84.0/ 1700
3A165-SE4B	2400	18.4 / 24.7	84.0/ 1700



◎ GENERAL ENGINE DATA

▶ Emission Level	EEC : StageV, EPA : Tier4 Final, Korea : Tier4
▶ Engine Type	3-Cylinder, 4-Cycle, In-line, Diesel, Water cooled, N/A
▶ Bore x Stroke	Ø87 x 92.4 mm
▶ Displacement	1.647 liters
▶ Compression Ratio	21.7 : 1
▶ Combustor Type	In-Direct Injection(Swirl Chamber)
▶ Rotation	Counter clockwise viewed from Flywheel
▶ Dimension (L x W x H)	615 x 495 x 656.5 mm
▶ Dry Weight	175kg (with Fan)
▶ High Idle Rpm	2800±50
▶ Low Idle Rpm	1050±50
▶ Aspiration	N/A
▶ Governor Type	Mechanical Centrifugal
▶ Injection timing	18° BTDC
▶ Alternator Capacity	12V-75A
▶ Firing order	1-2-3
▶ Flywheel housing	SAE No.4
▶ Flywheel	Clutch No.7-1/2

Specifications are subject to change without prior notice

■ CONVERSION TABLE

Power

$$\text{hp} = \text{Kw} \times 1.3405$$

$$\text{kW} = \text{hp} \times 0.7459$$

$$\text{kW} = [\text{torque(Nm)} \times \text{rpm}] / 9549$$

$$\text{hp} = [\text{torque(lb-ft)} \times \text{rpm}] / 5252$$

Torque

$$\text{Nm} = (9549 \times \text{Kw}) / \text{rpm}$$

$$\text{Nm} = 1.3558 \times \text{lb-ft}$$

$$\text{lb-ft} = (5252 \times \text{hp}) / \text{rpm}$$

$$\text{lb-ft} = 0.73756 \times \text{Nm}$$

$$\text{U.G gal} = \text{lit.} \times 0.264$$

$$\text{kW} = 0.2388 \text{ kcal/s}$$

$$\text{lb/PS.h} = \text{g/Kw.h} \times 0.00162$$

$$\text{cfm} = \text{m}^3/\text{min} \times 35.336$$



daedong

◆ ENGINE DIMENSION

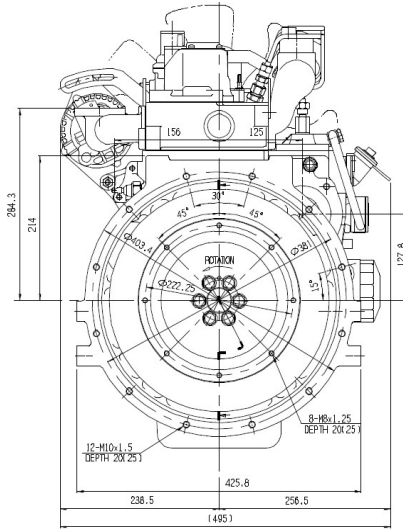
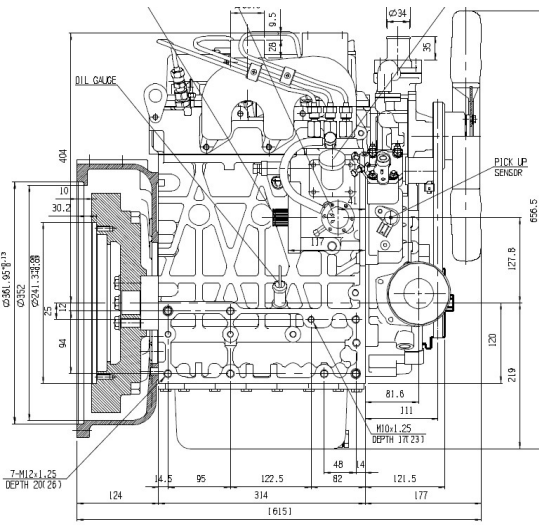

Designation	Length(L)	Width(W)	Height(H)	Dry weight
Value	615mm	495mm	656.5mm	175kg

◆ Performance Curve

3A165-SE4A

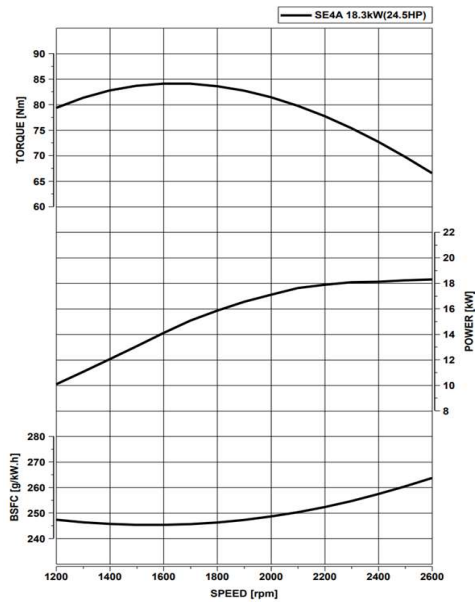

3A165-SE4B

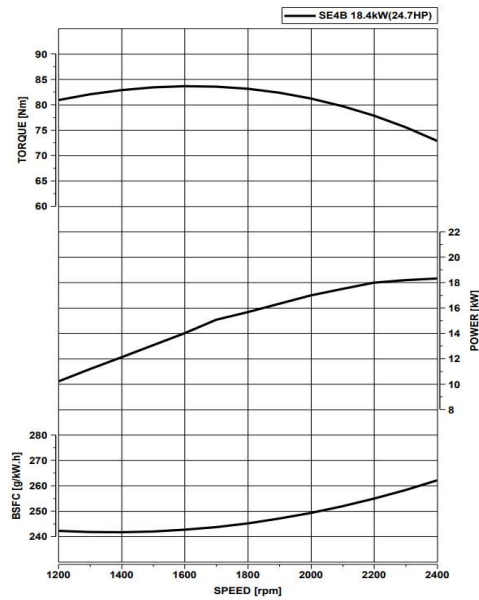

Revised on DEC 3, 2023



daedong