



3C100

Type	Rated RPM	Rated Power (kW/HP)	Max. Torque (N·m/rpm)
3C100LFS-U1	3000	16.4 / 22.0	54.0/ 2300
3C100LFS-U	3000	17.9 / 24.0	61.0/ 2300



◎ GENERAL ENGINE DATA

▶ Emission Level	EPA : Tier4(NTE)
▶ Engine Type	3-Cylinder, 4-Cycle, In-line, Diesel, Water cooled, N/A
▶ Bore x Stroke	Ø75 x 76 mm
▶ Displacement	1.007 liters
▶ Compression Ratio	21:1
▶ Combustor Type	In-Direct Injection(Swirl Chamber)
▶ Rotation	Counter clockwise viewed from Flywheel
▶ Dimension (L x W x H)	515 x 447 x 544 mm
▶ Dry Weight	100kg (with Fan)
▶ High Idle Rpm	3200±50
▶ Low Idle Rpm	1350±50
▶ Aspiration	N/A
▶ Governor Type	Electric Control (ECU)
▶ Injection timing	18° BTDC
▶ Alternator Capacity	12V-75A
▶ Firing order	1-2-3
▶ Flywheel housing	SAE No.5
▶ Flywheel	Clutch No.7-1/2

Specifications are subject to change without prior notice

■ CONVERSION TABLE

Power

$$\text{hp} = \text{Kw} \times 1.3405$$

$$\text{kW} = \text{hp} \times 0.7459$$

$$\text{kW} = [\text{torque(Nm)} \times \text{rpm}] / 9549$$

$$\text{hp} = [\text{torque(lb-ft)} \times \text{rpm}] / 5252$$

Torque

$$\text{Nm} = (9549 \times \text{Kw}) / \text{rpm}$$

$$\text{Nm} = 1.3558 \times \text{lb-ft}$$

$$\text{lb-ft} = (5252 \times \text{hp}) / \text{rpm}$$

$$\text{lb-ft} = 0.73756 \times \text{Nm}$$

$$\text{U.G gal} = \text{lit.} \times 0.264$$

$$\text{kW} = 0.2388 \text{ kcal/s}$$

$$\text{lb/PS.h} = \text{g/Kw.h} \times 0.00162$$

$$\text{cfm} = \text{m}^3/\text{min} \times 35.336$$

Revised on DEC 3, 2023





daedong

◆ ENGINE DIMENSION

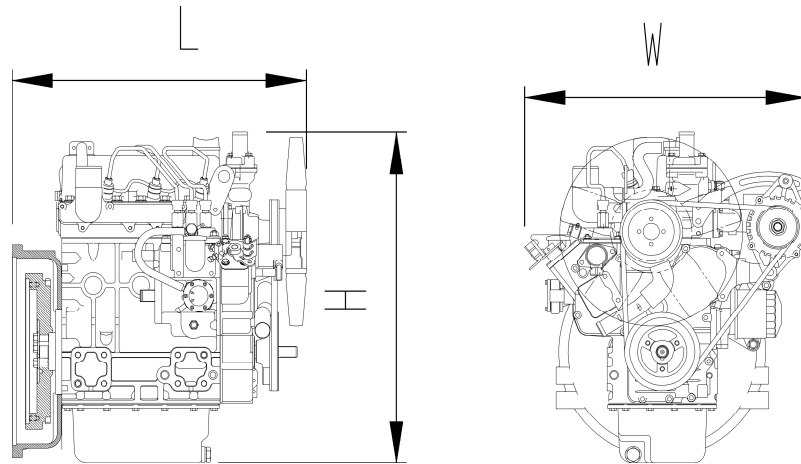

Designation	Length(L)	Width(W)	Height(H)	Dry weight
Value	502mm	447mm	544mm	100kg

◆ Performance Curve

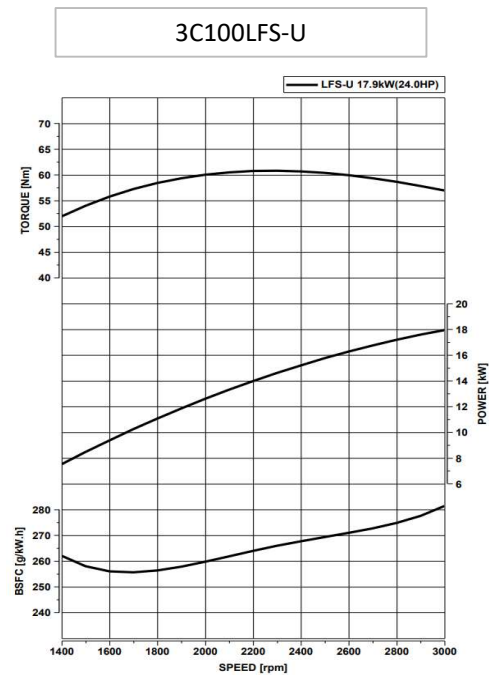
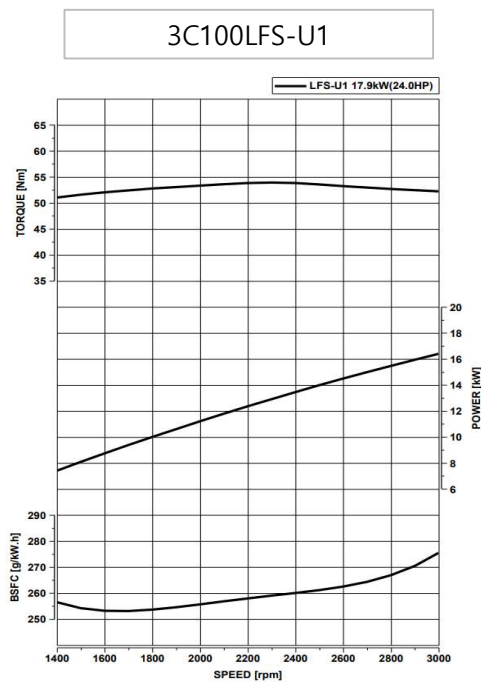

Revised on DEC 3, 2023



daedong