

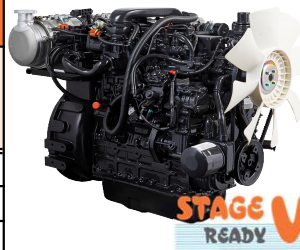

4H243TIG

Type	Rated RPM	Stand by (Kw / HP)	Prime (Kw / HP)
4H243TI-GE5A	1800	51.4 / 68.9	46.0 / 61.7
4H243TI-GE5B	1500	43.0 / 57.7	39.0 / 52.3



Ratings Definition

Emergency Standby and Prime power ratings adhere to ISO 8528 standards. Electric power (kWe) should account for factors such as cooling fan loss, alternator efficiency, altitude derating, and ambient temperature.

Standby Power Rating is meant for providing emergency power during utility outages. No overload capability is available for this rating and it should be sized for a maximum 80% average load factor, with a limit of 200 hours of operation per year. This includes less than 25 hours per year at Standby Power rating.

Prime Power Rating is suitable for unlimited annual hours in variable load application, with a 70% average of the rating within any 24-hour period. The total operating time at 100% Prime Power should not exceed 500 hours per year. Additionally, a 10% overload capability is allowed for up to 1 hour within a 12-hour period, but the total operating time at this overload should not surpass 25 hours per year.

GENERAL ENGINE DATA

▶ Emission Level	EEC : StageV, EPA : Tier4 Final, Korea : Tier4
▶ Engine Type	4-cylinder, 4-Cycle, Diesel, Water cooled, Turbo, IC
▶ Bore x Stroke	Ø87×102.4 mm
▶ Displacement	2.435 liters
▶ Compression Ratio	17.4±0.2 : 1
▶ Combustor Type	Common Rail Direct Injection(CRDI)
▶ Rotation	Counter clockwise viewed from Flywheel
▶ Dimension (L x W x H)	934.3 x 566.9 x 726.7 mm
▶ Dry Weight	295kg (with Fan and housing type)
▶ Aspiration	Turbo Charged & Intercooler
▶ Governor Type	Electric Control (ECU)
▶ Injection timing	Auto Control
▶ Alternator Capacity	12V-75A
▶ Firing order	1-3-2-4
▶ Flywheel housing	SAE No.4
▶ Flywheel	Clutch No.7-1/2
▶ After Treatment	CCRT(DOC+DPF)

Specifications are subject to change without prior notice

CONVERSION TABLE

Power

$$\text{hp} = \text{Kw} \times 1.3405$$

$$\text{kW} = \text{hp} \times 0.7459$$

$$\text{kW} = [\text{torque(Nm)} \times \text{rpm}] / 9549$$

$$\text{hp} = [\text{torque(lb-ft)} \times \text{rpm}] / 5252$$

Torque

$$\text{Nm} = (9549 \times \text{Kw}) / \text{rpm}$$

$$\text{Nm} = 1.3558 \times \text{lb-ft}$$

$$\text{lb-ft} = (5252 \times \text{hp}) / \text{rpm}$$

$$\text{lb-ft} = 0.73756 \times \text{Nm}$$

$$\text{U.G gal} = \text{lit.} \times 0.264$$

$$\text{kW} = 0.2388 \text{ kcal/s}$$

$$\text{lb/PS.h} = \text{g/Kw.h} \times 0.00162$$

$$\text{cfm} = \text{m}^3/\text{min} \times 35.336$$

Revised on DEC 3, 2023



◆ ENGINE DIMENSION

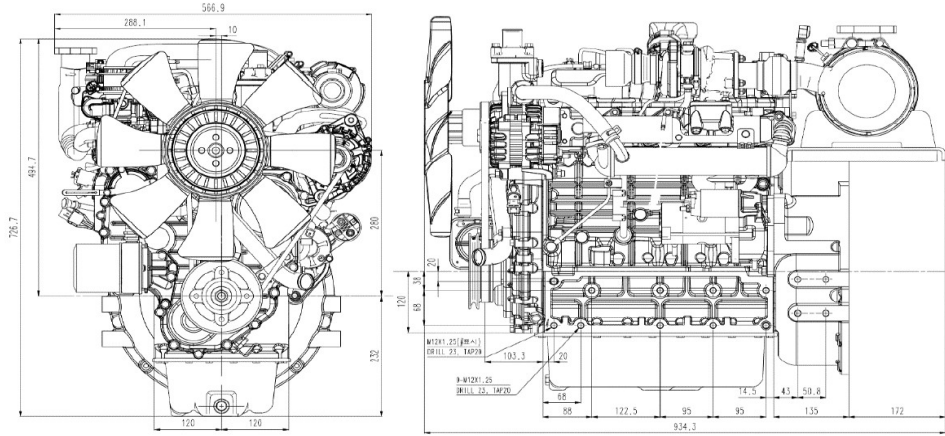

Designation	Length(L)	Width(W)	Height(H)	Dry weight
Value	934.3	566.9	726.7	295

Revised on DEC 3, 2023

