

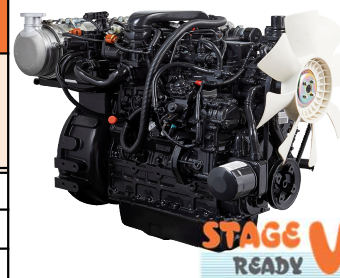

## 4H243T

| Type        | Rated RPM | Rated Power (kW/HP) | Max. Torque (N·m/rpm) |
|-------------|-----------|---------------------|-----------------------|
| 4H243T-SE5A | 2600      | 54.5 / 73.1         | 240.5 / 1700          |
| 4H243T-SE5B | 2600      | 49.5 / 66.4         | 220.0 / 1700          |
| 4H243T-SE5D | 2400      | 49.5 / 66.4         | 237.0 / 1700          |
| 4H243T-SE5C | 2600      | 45.0 / 60.3         | 210.0 / 1700          |



### ◎ GENERAL ENGINE DATA

|                         |   |
|-------------------------|---|
| ▶ Emission Level        | EEC : StageV, EPA : Tier4 Final, Korea : Tier4  |
| ▶ Engine Type           | 4-ylinder, 4-Cycle, Diesel, Water cooled, Turbo |
| ▶ Bore x Stroke         | Ø87×102.4 mm                                    |
| ▶ Displacement          | 2.435 liters                                    |
| ▶ Compression Ratio     | 17.4±0.2 : 1                                    |
| ▶ Combustor Type        | Common Rail Direct Injection(CRDI)              |
| ▶ Rotation              | Counter clockwise viewed from Flywheel          |
| ▶ Dimension (L x W x H) | 934.3 x 566.9 x 726.7 mm                        |
| ▶ Dry Weight            | 295kg (with Fan and housing type)               |
| ▶ High Idle Rpm         | 2750±50   |
| ▶ Low Idle Rpm          | 900±50  |
| ▶ Aspiration            | Turbo Charged                                   |
| ▶ Governor Type         | Electric Control (ECU)                          |
| ▶ Injection timing      | Auto Control                                    |
| ▶ Alternator Capacity   | 12V-75A   |
| ▶ Firing order          | 1-3-2-4   |
| ▶ Flywheel housing      | SAE No.4  |
| ▶ Flywheel              | Clutch No.7-1/2                                 |
| ▶ After Treatment       | CCRT(DOC+DPF)                                   |

Specifications are subject to change without prior notice

### ■ CONVERSION TABLE

#### Power

$$\text{hp} = \text{Kw} \times 1.3405$$

$$\text{kW} = \text{hp} \times 0.7459$$

$$\text{kW} = [\text{torque(Nm)} \times \text{rpm}]/9549$$

$$\text{hp} = [\text{torque(lb-ft)} \times \text{rpm}] / 5252$$

#### Torque

$$\text{Nm} = (9549 \times \text{Kw})/\text{rpm}$$

$$\text{Nm} = 1.3558 \times \text{lb-ft}$$

$$\text{lb-ft} = (5252 \times \text{hp})/\text{rpm}$$

$$\text{lb-ft} = 0.73756 \times \text{Nm}$$

$$\text{U.G gal} = \text{lit.} \times 0.264$$

$$\text{kW} = 0.2388 \text{ kcal/s}$$

$$\text{lb/PS.h} = \text{g/Kw.h} \times 0.00162$$

$$\text{cfm} = \text{m}^3/\text{min} \times 35.336$$



**daedong**

◆ ENGINE DIMENSION

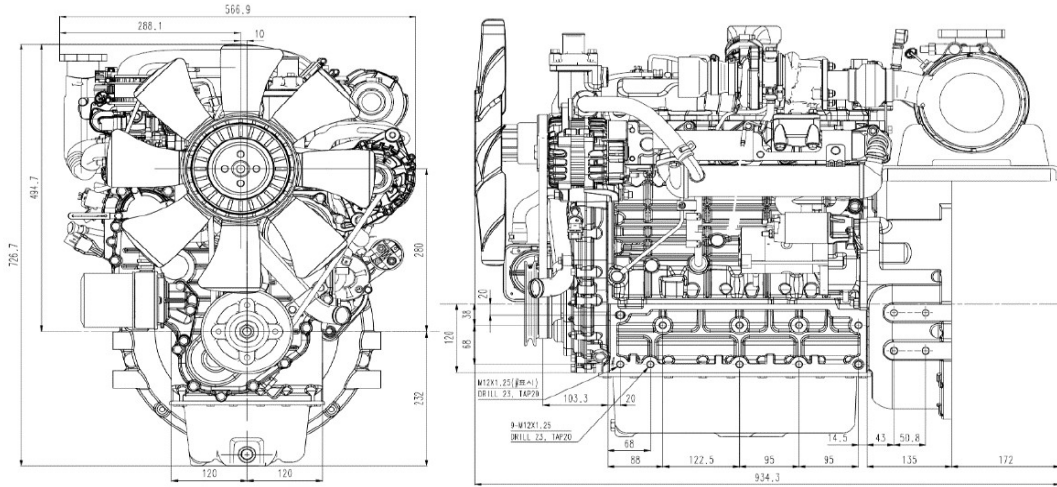

| Designation | Length(L) | Width(W) | Height(H) | Dry weight |
|-------------|-----------|----------|-----------|------------|
| Value       | 934.3     | 566.9    | 726.7     | 295        |

◆ Performance Curve

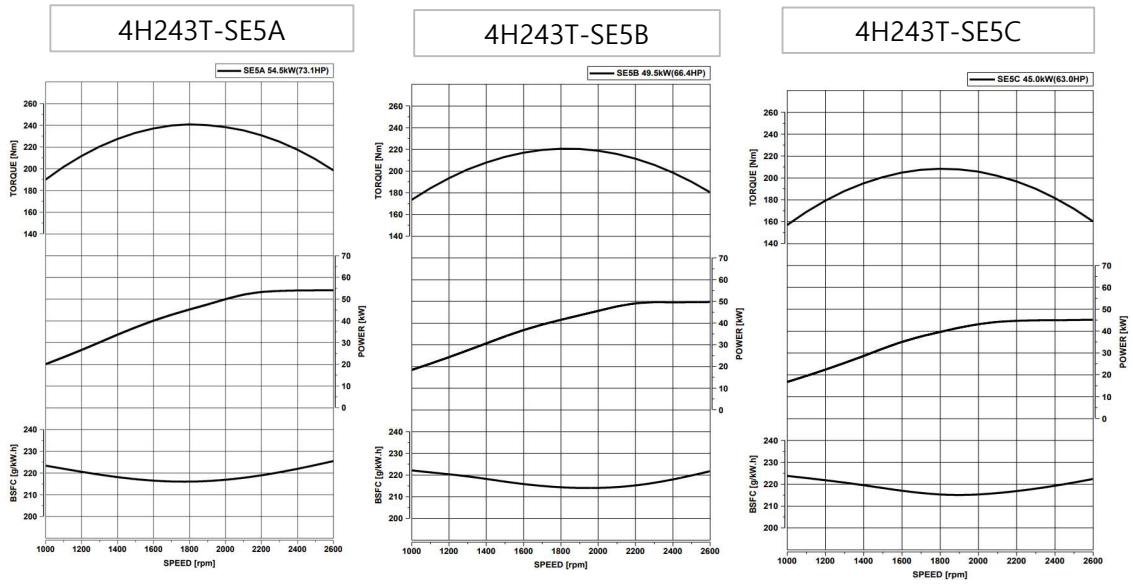

Revised on DEC 3, 2023



**daedong**